



MARINE DIESEL ENGINES

# IN/OUTBOARD MARINE ENGINE 42HPEP

## Models:

42HPEP 350 - 42HPEP 330 - 42HPEP 300

42HPEP 280 - 42HPEP 250 - 42HPEP 150



The 42HPEP engine was developed on a VM engine basis.

## Dimensions | FNM 42HPEP with BRAVO 3

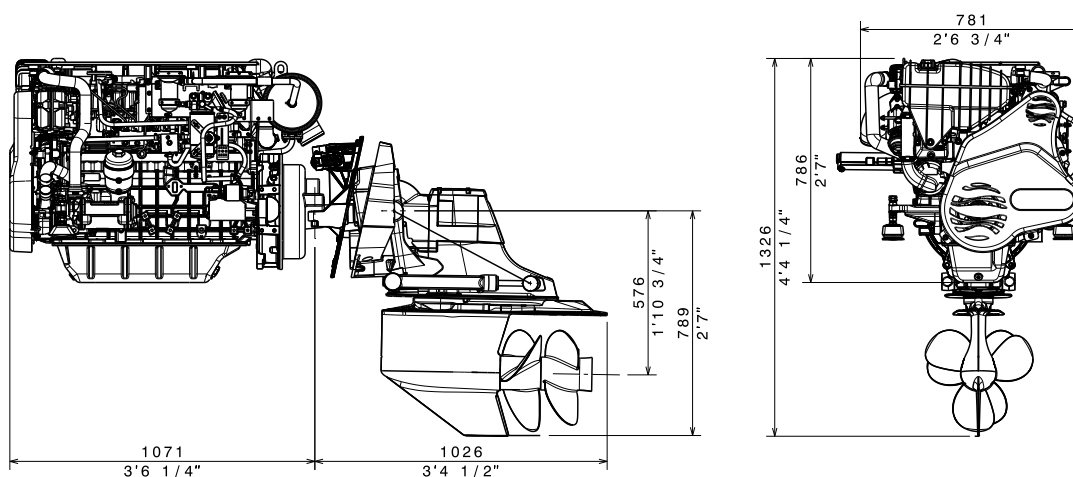

## Technical data

Engine model	42 HPEP 350	42 HPEP 330	42 HPEP 300	42 HPEP 280	42 HPEP 250	42 HPEP 150
<b>Max Power</b>	257 kW 350 HP 3800 rpm	242,6 kW 330 HP 3800 rpm	220,6 kW 300 HP 3800 rpm	206 kW 280 HP 3800 rpm	184 kW 250 HP 3800 rpm	110 kW 150 HP 3800 rpm
<b>Max Torque</b>	700 Nm 71.4 Kgm 2700 rpm	657 Nm 67 Kgm 2700 rpm	657 Nm 67 Kgm 2700 rpm	657 Nm 67 Kgm 2700 rpm	530 Nm 54 Kgm 2700 rpm	330 Nm 33.6 Kgm 2700 rpm
<b>Number of cylinders</b>	6 in line					
<b>Displacement [l] - (cc)</b>	4.2 - 4.164					
<b>Bore and Stroke (mm) - (in)</b>	[94x100] - (3.7x4.09)					
<b>Dry weight [kg]</b>	460					
<b>Cooling</b>	Water					
<b>Combustion</b>	Direct Injection Common Rail					
<b>Induction</b>	Turbocharged and intercooled					
<b>Emissions compliance</b>	Directive 2013/53/UE					

Technical data according to ISO8665. Fuel complies EN590. Merchant fuel may differ in specification and may influence engine power output and consumption. Production tolerance within 5% (of power). Not all models, standard equipment and accessories are available in all countries. All specifications are subject to change without notice.

## Standard technical equipment

- SAE flywheel housing
- Starter motor 12V - 2,3kW
- Alternator 12V-110A
- Oil and fuel filters
- Air filter
- Freshwater engine cooling system with seawater heat exchanger
- Engine lubricating oil cooled by heat exchanger seawater cooled
- Freshwater cooled exhaust manifold and freshwater turbocharger
- Bronze seawater circulating pump with impeller in special rubber
- Centrifugal pump for freshwater circulation
- Drain oil pump
- Expansion tank integrated
- Stainless steel exhaust gas/seawater mixer
- Flexible mounts
- Electrical instrument panel with alarms
- 8m. panel cable extension
- White paint finish

## Optionals

- Single or double electronic CANBUS
- Boiler kit for heating
- Various lenght panel extension
- Second control panel for flybridge installations
- Fuel and seawater filters
- BRAVO X-1 stern drive Red. 1,65:1 or BRAVO 2 Red. 2:1 - BRAVO 3 Red. 2:1
- Stainless steel propeller for BRAVO X-1
- Aluminium propeller for BRAVO X-2
- Stainless steel propeller for BRAVO X-3
- Multiple Sterndrive Steering Tie for twin-engine
- Alignment tool
- Coupler kit
- NMEA2000 compatibility kit
- Wide range of additional instruments

## Performance curves

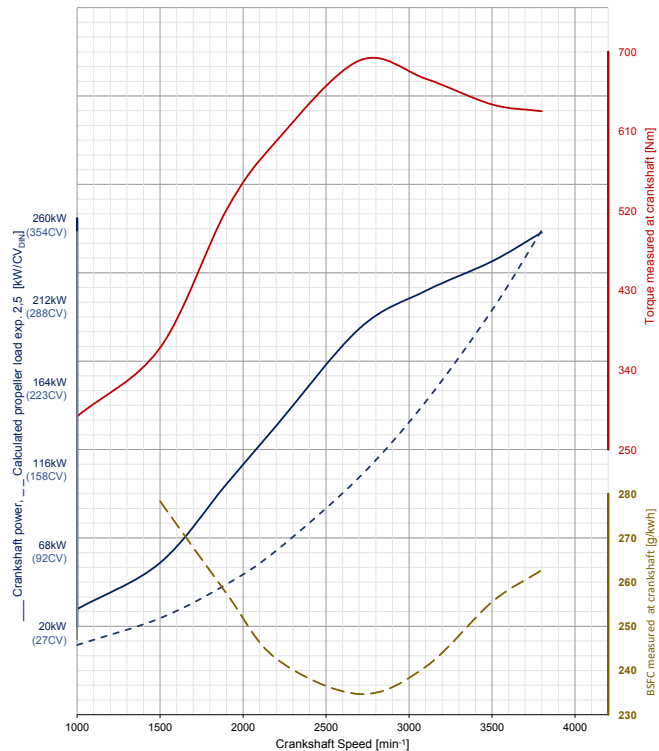

Referred to **42HPE 350**

## Panel instrument CANBUS

Panel Instrument **high brightness 5" TFT display**, with **touchscreen** and a very simple and intuitive interface.

- Engine data acquisition with CANBUS J1939 interface.
- Data acquisition from traditional sensors for up to eight analog inputs, five digital inputs and one frequency input
- Acquisition of navigation data with NMEA0183 interface
- Up to five relay command outputs for signals and simple activations
- Alarm monitoring according to approved safety standards
- Automatic brightness adjustment and day / night mode
- USB local connectivity for firmware update and configuration

The unit is supplied already programmed and ready to work.

